

Pan Pearl River Delta Physics Olympiad 2026

2026 年泛珠三角及中华名校物理奥林匹克邀请赛

Sponsored by Institute for Advanced Study, HKUST

香港科技大学高等研究院赞助

Simplified Chinese Part-2 (Total 2 Problems, 60 Points)

简体版卷-2 (共 2 题, 60 分)

(1:30 pm – 5:00 pm, 21 February 2026)

You can detach the **answer sheet** from the last page of the question paper.

你可以将**答题纸**从试卷最后一页撕下来。

All final answers should be written in the **answer sheet**.

所有最后答案要写在**答题纸**上。

All detailed answers should be written in the **answer book**.

所有详细答案要写在**答题簿**上。

There are 2 problems. Please answer each problem starting on a **new page**.

共有 2 题, 每答 1 题, 须采用**新一页纸**。

Please answer on each page using a **single column**. Do not use two columns on a single page.

每页纸请用**单一直列**的方式答题。不可以在一页纸上以双直列方式答题。

Please answer on **only one page** of each sheet. Do not use both pages of the same sheet.

每张纸**单页**作答。不可以双页作答。

Rough work can be written in the answer book. Please cross out the rough work after answering the questions. No working sheets for rough work will be distributed.

草稿可以写在答题簿上, 答题后要在草稿上划上交叉, 不会另发草稿纸。

If the answer book is not enough for your work, you can raise your hand. Extra answer books will be provided. Your name and examination number should be written on all answer books.

考试中答题簿不够可以举手要, 所有答题簿都要写下姓名和考号。

At the end of the competition, please put the **question paper and answer sheet** inside the answer book. If you have extra answer books, they should also be put inside the first answer book.

比赛结束时, 请把考卷和答题纸夹在答题簿里面, 如有额外的答题簿也要夹在第一本答题簿里面。

Problem 1 题 1 [30]:

In this problem we consider how current flows in conductors in direct current (DC) and alternating current (AC) settings. An azimuthal symmetrical time independent current density $J(r) > 0$ flows through a long and straight cylindrical wire with radius a along $+z$ direction. We first consider a classical model of the current. In the lab frame, denoted as S , we imagine the electrons flow in opposite direction of the current with a uniform non-relativistic drift velocity $v \ll c$ towards $-z$ direction, among the fixed uniformly distributed positive charges. We assume the number density of electrons in the wire could vary with r and is denoted as $n_e(r)$ while the positive charges have a uniform number density, n_p . We also assume the wire is non-magnetic.

在本题中，我们将探讨直流电（DC）和交流电（AC）环境下导体中电流流动的物理机制。考虑一根沿 $+z$ 方向无限长直圆柱形导线，半径为 a 。导线中流过具有轴对称性且与时间无关的电流密度 $J(r) > 0$ 。我们首先考虑电流的一个经典模型。在实验室参考系（记为 S ）中，我们设想电子在均匀分布的固定正电荷背景中，以均匀的非相对论漂移速度 $v \ll c$ 沿 $-z$ 方向（即与电流方向相反）流动。假设导线内的电子数密度随半径 r 变化，记为 $n_e(r)$ ；而正电荷具有均匀的数密度，记为 n_p 。同时假设该导线是非磁性的。

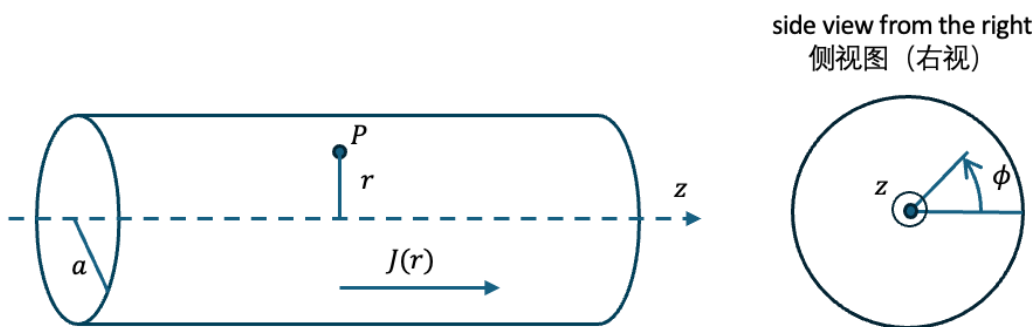

(a)	Write down the current density $J(r)$ in terms of electron charge e , $n_e(r)$, r and v . 试用电子电荷 e 、 $n_e(r)$ 和 v 写出电流密度 $J(r)$ 的表达式。	1 Points 1 分
(b) Consider a point P which is $r < a$ distance away from the z axis and where $J(r)$ is non-zero, (b) 考虑一个距离 z 轴距离为 r （其中 $r < a$ ）的点 P ，而其中 $J(r)$ 为非零：		
(bi)	find the magnitude of the magnetic field, in terms of an integral involving $e, v, n_e(r), r$ and other universal constants and indicate its direction; 求该点的磁感应强度大小，结果用包含 $e, v, n_e(r), r$ 及其他普适常数的积分形式表示，并指出其方向。	1 Points 1 分
(bii)	find the magnitude of the electric field, in terms of an integral involving $e, v, n_p, n_e(r), r$ and other universal constants and indicate its direction. 求该点的电场强度大小，结果用包含 $e, v, n_p, n_e(r), r$ 及其他普适常数的积分形式表示，并指出其方向。	1 Points 1 分
(c)	When the current flows steadily, find the electron density $n_e(r)$ for $0 < r < a$ for a given v , in terms of n_p, e, v, a and other universal constants. 当电流稳定流动时，对于给定的速度 v ，求 $0 < r < a$ 范围内的电子数密度 $n_e(r)$ 。结果用包含 e, v, n_p 和 a 及其他普适常数表示。	4 Points 4 分
(d)	Sketch net charge distribution along the radial direction outward for $0 < r < a$. 绘出 $0 < r < a$ 范围内沿径向向外的净电荷分布图。	1 Points 1 分
(e)	Find the voltage difference between surface of the wire and the center of the wire, in terms of electron charge e , n_p, a, v and other universal constants. The (surface / center) has a higher voltage. (circle the correct answer.) 求导线表面与导线中心之间的电压差（电势差），结果用包含 e, v, n_p 和 a 及其他普适常数表示。[选择题]（表面 / 中心）具有较高的电势。（圈出正确答案）	2 Points 2 分

Now let's look at the current in a reference frame which moves as the same velocity as the electrons do, denote the reference frame as S' . Therefore, in the S' frame, the electrons are stationary and the positive charge and the wire is moving at v towards $+z$ direction.

现在，让我们在一个与电子同速移动的参考系中观察电流，将该参考系记为 S' 。因此，在 S' 系中，电子是静止的，而正电荷和导线以速度 v 向 $+z$ 方向移动。

(f)	In the S' frame, calculate the net force acting on the electron at P , in terms of electron charge e , n_p and v . 在 S' 系中，计算作用在 P 点电子上的合力，结果用电子电荷 e , n_p 和 v 表示。	1 Points 1 分
-----	---	-----------------

There is a discrepancy between the motion of the electrons in S and S' ! Should the electrons flow steady or should they subject to non-zero net force at P ? This discrepancy will become larger when v increases, too.

Suppose in the future we discover a new material in which the drift velocity can be comparable to the speed of light. Now we need to consider the relativistic effect. Let's hold on to the observation that when the current is flowing steadily, the wire is overall neutral in the S frame.

此处电子在 S 系和 S' 系中的运动状态出现了矛盾！电子在 P 点究竟应该是稳定流动的，还是应该受到非零合力的作用？当 v 增大时，这种矛盾会变得更大。假设未来我们发现了一种新材料，其中的漂移速度可以与光速相比拟。现在我们需要考虑相对论效应。让我们坚持这一观测事实：当电流稳定流动时，导线在 S 系中整体是电中性的。

(g)	The number density of the positive charge in S frame and that in S' frame are denoted as n_p and n'_p , respectively. Find the relation between n_p and n'_p in terms of v and c . 设 S 系中的正电荷数密度为 n_p ， S' 系中的正电荷数密度为 n'_p 。求 n_p 与 n'_p 之间的关系，用 v 和 c 表示。	1 Points 1 分
(h)	Explicitly show in the S' frame, the net force on the electrons at P become zero with consideration of relativistic effect. 明确证明：在考虑相对论效应后，在 S' 系中作用于 P 点电子的合力变为零。	2 Points 2 分

From this point forward, we will disregard relativistic effects.

从现在起，我们将忽略相对论效应。

For conductors in reality, all of them have a very small drift velocity, thus, relativistic effect can actually be ignored. In addition, the magnetic force on the electrons is also negligible. Therefore, in DC, we can assume the current density is uniform throughout the cross-section of the conductor.

对于现实中的导体，其漂移速度极小，因此相对论效应实际上可以忽略不计。此外，作用在电子上的磁场力也是可以忽略的。因此，在直流电（DC）情况中，我们可以假设电流密度在导体横截面上是均匀的。

In the following, we will consider a conductor of an infinitely large (along x and z) slab with width D as shown below. The z -axis is in the middle of the slab. The conducting slab obeys Ohm's Law $\vec{J} = \sigma \vec{E}$, with conductivity $\sigma = 3.77 \times 10^7 \Omega^{-1}m^{-1}$. The dielectric constant of the slab is $K = 1$. We can ignore the relativistic effect from here on.

接下来，我们将考虑一个在 x 和 z 方向上无限大、厚度为 D 的平板导体，如下图所示。 z 轴位于板的中间。该导体板遵循欧姆定律 $J = \sigma E$ ，电导率 $\sigma = 3.77 \times 10^7 \Omega^{-1}m^{-1}$ 。导体板的介电常数为 $K = 1$ 。从这里开始，我们可以忽略相对论效应。

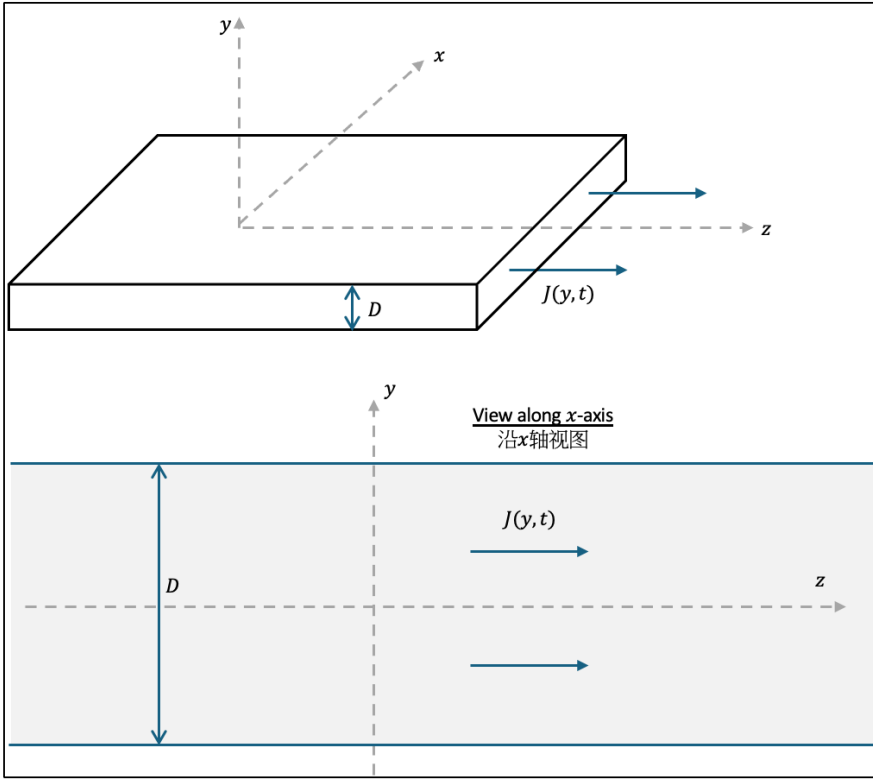

To warm up, we consider a uniform current density with increasing magnitude as $J(y, t) = j_0 + \alpha t$, where j_0 and α are positive constants and $j_0 \gg \frac{\alpha \epsilon_0}{\sigma}$.

作为热身，我们首先考虑一个大小随时间增加的均匀电流密度： $J(y, t) = j_0 + \alpha t$ ，其中 j_0 和 α 为正常数，且 $j_0 \gg \alpha \epsilon_0 / \sigma$ 。

(i)	Find the magnetic field due to the current as a function of y and t in the conductor 求导体内部由该电流产生的磁感应强度，表示为 y 和 t 的函数。	2 Points 2分
(j)	Find the difference in the z-component of the electric field $\Delta E_z = E_z(y = \frac{D}{2}) - E_z(y = \frac{D}{4})$ at any time, taking $E > 0$ as \vec{E} points towards the $+z$ direction. 求任意时刻 z 方向电场强度的差值 $\Delta E_z = E_z(y = D/2) - E_z(y = D/4)$ 。规定 E 指向 $+z$ 方向为 $E > 0$ 。	2 Points 2分

According to the Ohm's law, this yields a difference in the current density along y and this is referred to as skin effect that, for time varying current, the current density concentrates at the surface of the conductor. This effect occurs commonly in AC power transmission wire.

根据欧姆定律，这将导致电流密度沿 y 方向产生差异，这就是所谓的趋肤效应 (Skin effect)：对于时变电流，电流密度集中在导体表面。这种现象在交流输电线路中很常见。

Now we consider an alternating current (AC) with frequency $f = 50\text{Hz}$ passing through the slab. The current density flows along z -axis is $J(y, t) = \text{Re}(j(y)e^{i\omega t})$.

现在我们考虑频率 $f = 50\text{Hz}$ 的交流电 (AC) 通过该平板。沿 z 轴流动的电流密度为 $J(y, t) = \text{Re}(j(y)e^{i\omega t})$ 。

(k)	Show that for the given parameters, the displacement current is much smaller than the free current. 证明在给定参数下，位移电流远小于自由电流 (传导电流)。	1 Points 1分
(l)	Derive a differential equation for $j(y)$ by ignoring the displacement current. 忽略位移电流，推导 $j(y)$ 的微分方程。	2 Points 2分
(m)	In the limit the slab is very thick $D \gg \sqrt{1/\sigma\mu_0\omega}$ and we are interested in the current near the bottom edge $(y + \frac{D}{2}) \ll \sqrt{1/\sigma\mu_0\omega}$, solve for the current density $j(y)$ for $j(\frac{D}{2}) = j(-\frac{D}{2}) = j_0 = 1\text{Am}^{-2}$. Express $j(y)$ in terms of $\sigma, \epsilon_0, \mu_0, \omega, D$ and j_0	4 Points 4分

	在平板非常厚的极限情况下 $D \gg \sqrt{1/\sigma\mu_0\omega}$ ，我们感兴趣的是底部边缘附近 $(y + \frac{D}{2}) \ll \sqrt{1/\sigma\mu_0\omega}$ 的电流。求解 $j(y)$ 。边界条件为 $j(D/2) = j(-D/2) = j_0 = 1 \text{ A} \cdot \text{m}^{-2}$ 。用 $\sigma, \epsilon_0, \mu_0, \omega, D$ 和 j_0 表示 $j(y)$ 。	
(n)	Write down $J(y, t)$ in terms of $\sigma, \epsilon_0, \mu_0, \omega, D$ and j_0 and sketch the current distribution $J(y, 0)$ for $-\frac{D}{2} \leq y \leq 0$ for $D = 10 \text{ cm}$ and the given parameters. 写下 $J(y, t)$ 。用 $\sigma, \epsilon_0, \mu_0, \omega, D$ 和 j_0 表示 $J(y, t)$ 。并对于 $D = 10 \text{ cm}$ 及给定参数，绘制草图绘出 $-D/2 \leq y \leq 0$ 范围内的电流分布 $J(y, 0)$ 图。	2 Points 2 分

Suppose the frequency of the AC is very high such that the displacement current is much larger than the free current.
假设交流电的频率非常高，以至于位移电流远大于自由电流。

(o)	Show that a standing wave in $j(y)$ will be formed in the slab along y and find the wavelength of the standing wave in terms of ω . Express the wavelength in terms of ω and other universal constants. 证明 $j(y)$ 在平板内沿 y 方向将形成驻波，并求出该驻波的波长，用 ω 及其他普适常数表示。	3 Points 3 分
-----	--	-----------------

Problem 2 题 2 [30]:

In strong-field physics, there is an intriguing phenomenon: an intense laser pulse can ionize air and excite an air plasma wave. The ponderomotive force associated with the pulse will exert on free electrons (positive ions can be viewed as stationary), thereby affecting propagation of the laser pulse itself. We consider a simplified one-dimensional model: a thin air plasma slab extends along the x -direction, with electron number density labeled as $n_e(x, t)$. A linear-polarized laser with carrier frequency ω is incident in such a way that it first creates air plasma and then propagates in it along the z -direction. The electric field distribution the laser field in the transverse direction (x -direction) can be approximated as a Gaussian profile:

$$\mathbf{E}(x, t) = \hat{x}E_0 e^{-x^2/L^2} \cos(\omega t),$$

where E_0 is the peak amplitude of laser pulse and L is the characteristic width of the mode in the transverse direction in air. We assume that the electrons are nonrelativistic, $v \ll c$, and that electron-electron collision and electron-ion collision can be neglected.

在强场物理中有一个颇为有趣的现象：强激光脉冲能够电离空气并激发空气等离子体波。光脉冲的 **Ponderomotive Force (有质动力)** 会额外作用在自由电子上(正离子可以近似认为静止)，产生新的分布，从而对波的传播产生显著影响。考虑一个简化的一维模型：在沿 x 方向分布的一薄层空气等离子体中，电子数密度记为 $n_e(x, t)$ 。一束载频为 ω 的线偏振激光以适当方式入射，激发出沿 z 方向传播的空气等离子体波。在空气中的某一部局区域内，该等离子体波在横向 (x 方向) 上的电场分布可以近似为一高斯分布：

$$\mathbf{E}(x, t) = \hat{x}E_0 e^{-x^2/L^2} \cos(\omega t),$$

其中 E_0 为电场振幅峰值， L 为该模式在空气中横向分布的特征宽度。可假设电子速度处于非相对论区间 $v \ll c$ ，并忽略碰撞效应。

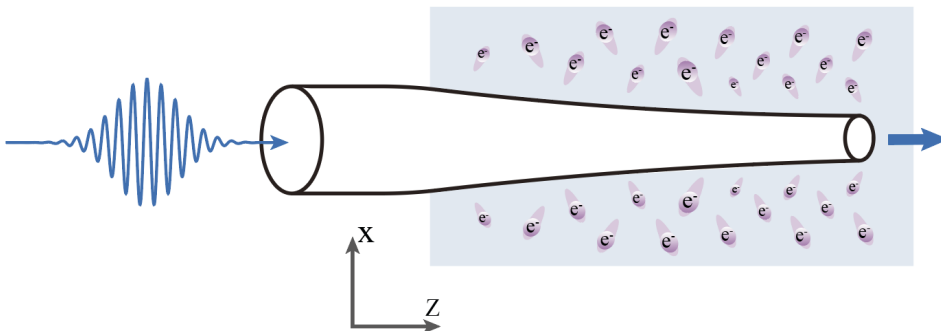

(a)	Consider an electron with charge $-e$ and mass m_e , initially at rest at the origin. In a rapidly oscillating electric field $\mathbf{E}(x, t)$, the ponderomotive potential $U_p(x)$ is defined as the cycle-averaged kinetic energy of the driven oscillatory motion of the electron. This definition is valid in the limit where the field envelope in the propagation direction (z axis) varies much more slowly than the optical field. Write down the equation of motion for the electron in the given field and use it to derive an explicit expression	6 Points 6 分
-----	---	-----------------

	<p>for $U_p(x)$ in terms of x, E_0, L, and the relevant physical constants.</p> <p>考虑一电子，其电荷为 $-e$、质量为 m_e，初始速度与初始位置均为 0。处于快速振荡电场 $\mathbf{E}(x, t)$ 中时，定义其有质动力势 $U_p(x)$ 为该电子在驱动振荡过程中的周期平均动能，此定义在电场的纵向（z 方向）分布的包络随时间变化远慢于光学周期的极限下成立。请写出该电子在给定电场中的运动方程，并由此推导出 $U_p(x)$ 关于 x, E_0, L 及相关物理常数的显式表达式。</p>	
(b)	<p>In the presence of the ponderomotive potential, the electrons will experience an effective force, the ponderomotive force. Find the x-component $F_{p,x}(x)$ of this force. Sketch qualitatively the spatial profile of $U_p(x)$. Explain your reasoning briefly in one or two sentences.</p> <p>在有质动力势存在的情况下，电子会感受到额外的有质动力。请写出有质动力 $F_{p,x}(x)$ 在 x 方向上的分量 $F_{p,x}(x)$，并说明这一有质动力的方向。定性画出 $U_p(x)$ 随 x 的分布曲线。并用一到两句话简要说明理由。</p>	6 Points 6 分
(c)	<p>Assume that on the slow time scale far longer the period of the optical field, the electrons can be treated as a hot fluid, to which an electron temperature T_e can be assigned. And those electrons may strike a quasi-static equilibrium due to the coexisting ponderomotive force and the thermal pressure along the x-direction. Neglecting gravity and the motion of the ion. The electron pressure is expressed</p> $p_e = n_e k_B T_e$ <p>On the slow time scale, the force balance condition reads</p> $-\frac{\partial p_e}{\partial x} + n_e(x) F_{p,x}(x) = 0$ <p>Derive the differential equation relating $n_e(x)$ to $U_p(x)$, and solve for the equilibrium electron density distribution $n_e(x)$. Derive the differential equation relating $n_e(x)$ to $U_p(x)$, and solve for the equilibrium electron density distribution $n_e(x)$, using n_0 as the reference electron density as $x \rightarrow \infty$</p> <p>假设在包络的慢时间尺度上，电子可以被视为温度为 T_e 的热流体，并在有质动力与沿 x 方向的压力梯度之间达到准静态平衡。忽略重力和离子运动。其中电子压力为</p> $p_e = n_e k_B T_e$ <p>利用慢时间尺度下的受力平衡条件：</p> $-\frac{\partial p_e}{\partial x} + n_e(x) F_{p,x}(x) = 0,$ <p>推导出 $n_e(x)$ 与 $U_p(x)$ 之间的微分方程，并求解平衡时电子密度 $n_e(x)$。结果请用 $x \rightarrow \infty$ 时的参考电子密度 n_0 表示。</p>	5 Points 5 分
(d)	<p>Using the expression for $U_p(x)$ obtained in part (a), find the explicit form of $n_e(x)$ in terms of x, E_0, L, T_e and other necessary constants. Discuss how the width of the electron depletion region (i.e., the region where n_e is significantly reduced) scales with L and E_0.</p> <p>利用 (a) 部分得到的 $U_p(x)$，将 $n_e(x)$ 显式写成关于 x, E_0, L, T_e 及物理常数的函数。并讨论电子空穴区（即 n_e 显著降低的区域）的宽度如何依赖于 L 和 E_0。</p>	3 Points 3 分
(e)	<p>In practice, as electrons redistribute, the local dielectric environment will vary as well. Such change will, in turn, affect the spatial profile and propagation of the laser field. Assuming $U_p(x) \ll k_B T_e$, and using the electron density distribution $n_e(x)$ obtained in part (c), the corresponding local plasma frequency can be derived as follows:</p> $\omega_p^2(x) = \frac{n_e(x) e^2}{\epsilon_0 m_e}$ <p>(i) please construction microscopic model to derive the spatial dependent dielectric function $\epsilon_r(x)$.</p> <p>(ii) please determine is the laser beam will be self-converging or self-diverging when propagating inside the plasma.</p> <p>(iii) suppose the light-driven redistribution of electron density has negligible z-dependence, and given the effective interaction length of the plasma is d. Please find the effective focal length f of this self-focusing (self-defocusing) “device”.</p> <p>在实际情况下，随着电子的迁移，局域的介电环境会随之改变，从而反过来影响光场的空间分布。假设 $U_p(x) \ll k_B T_e$，并根据 (c) 中得到的电子密度分布 $n_e(x)$，可得到相应的局域等离子体频率</p> $\omega_p^2(x) = \frac{n_e(x) e^2}{\epsilon_0 m_e}$ <p>(i) 请建立微观模型，并推导出相对介电常数 $\epsilon_r(x)$ 的表达式（不考虑碰撞，散射引起的耗散）。</p> <p>(ii) 激光束会发生自聚焦还是自发散行为，请给出定性解释。</p> <p>(iii) 假设有光场作用下的等离子体状态不随 z 坐标（纵向）持续发生变化，且等离子体中相互作用的有效长度为 d，请求出该自聚焦（或自发散）“器件”的等效焦距 f 的表达式。</p>	10 Points 10 分

Name: 姓名: _____

Number: 考号: _____

Problem 1 (問題 1) [30 分]

a [1] $J(r) =$	(bi) [1] 磁感应强度 magnitude of the magnetic field
(bii) [1] 电场强度 magnitude of the electric field	(c) [4] $n_e(r) =$
(d) [1] Please sketch the graphs on the answer book. 请在答案册上绘制图表。	(e) [2] 电压差 Voltage difference (Surface / Center) has a higher voltage. (circle the correct answer.) (表面 / 中心) 具有较高的电势。(圈出正确答案)
(f) [1] net force acting on electron at P P 点电子上的合力	(g) [1] relation between n_p and n'_p : n_p 与 n'_p 之间的关系:
(h) [2] Please write down the proof in the answer book 请在答案册上写下证明。	(i) [2] magnetic field 磁感应强度
(j) [2] $\Delta E_z =$	(k) Please write down the proof in the answer book [1] 请在答案册上写下证明。
(l) [2] Differential equation of $j(y)$: $j(y)$ 的微分方程:	(m) [4] $j(y) =$
(n) [2] Please sketch the graphs on the answer book. 请在答案册上绘制图表。	(o) [3] wavelength 波长 =

Problem 2 (問題 2) [30 分]

<p>(a) [6] the equation of motion for the electron: 电子的运动方程:</p>	<p>(a) $U_p(x) =$</p>
<p>(b) [6] $F_{p,x}(x) =$</p>	<p>(b) Please sketch the spatial profile of $U_p(x)$ on the answer book. 请在答案册上绘制画出 $U_p(x)$ 随 x 的分布曲线。</p>
<p>(c) [5] differential equation relating $n_e(x)$ to $U_p(x)$: $n_e(x)$ 与 $U_p(x)$ 之间的微分方程:</p>	<p>(c) $n_e(x) =$</p>
<p>(d) [3] $n_e(x) =$</p>	<p>(d) the width of the electron depletion region: 电子空穴区的宽度:</p>
<p>(ei) [10] $\epsilon_r(x) =$</p>	<p>(eii) circle the correct answer: 圈出正确答案: converging or diverging 自聚焦 还是 自发散</p>
<p>e(iii) $f =$</p>	